



Programmable Controller

MELSEC iQ-R
series

MELSEC iQ-R HART-Enabled Analog-Digital Converter Module User's Manual (Startup)

-R60ADI8-HA
-SW1DNN-HARTCDTM-BD (CommDTM for R60ADI8-HA)



SAFETY PRECAUTIONS

(Read these precautions before using this product.)

Before using this product, please read this manual and the relevant manuals carefully and pay full attention to safety to handle the product correctly.

The precautions given in this manual are concerned with this product only. For the safety precautions of the programmable controller system, refer to the MELSEC iQ-R Module Configuration Manual.

In this manual, the safety precautions are classified into two levels: "⚠ WARNING" and "⚠ CAUTION".

 WARNING	Indicates that incorrect handling may cause hazardous conditions, resulting in death or severe injury.
 CAUTION	Indicates that incorrect handling may cause hazardous conditions, resulting in minor or moderate injury or property damage.

Under some circumstances, failure to observe the precautions given under "⚠ CAUTION" may lead to serious consequences.

Observe the precautions of both levels because they are important for personal and system safety.

Make sure that the end users read this manual and then keep the manual in a safe place for future reference.

[Design Precautions]

WARNING

- Configure safety circuits external to the programmable controller to ensure that the entire system operates safely even when a fault occurs in the external power supply or the programmable controller. Failure to do so may result in an accident due to an incorrect output or malfunction.
 - (1) Emergency stop circuits, protection circuits, and protective interlock circuits for conflicting operations (such as forward/reverse rotations or upper/lower limit positioning) must be configured external to the programmable controller.
 - (2) When the programmable controller detects an abnormal condition, it stops the operation and all outputs are:
 - Turned off if the overcurrent or overvoltage protection of the power supply module is activated.
 - Held or turned off according to the parameter setting if the self-diagnostic function of the CPU module detects an error such as a watchdog timer error.
 - (3) All outputs may be turned on if an error occurs in a part, such as an I/O control part, where the CPU module cannot detect any error. To ensure safety operation in such a case, provide a safety mechanism or a fail-safe circuit external to the programmable controller. For a fail-safe circuit example, refer to "General Safety Requirements" in the MELSEC iQ-R Module Configuration Manual.
 - (4) Outputs may remain on or off due to a failure of a component such as a relay and transistor in an output circuit. Configure an external circuit for monitoring output signals that could cause a serious accident.
 - In an output circuit, when a load current exceeding the rated current or an overcurrent caused by a load short-circuit flows for a long time, it may cause smoke and fire. To prevent this, configure an external safety circuit, such as a fuse.
 - Configure a circuit so that the programmable controller is turned on first and then the external power supply. If the external power supply is turned on first, an accident may occur due to an incorrect output or malfunction.
 - For the operating status of each station after a communication failure, refer to manuals relevant to the network. Incorrect output or malfunction due to a communication failure may result in an accident.
-

[Design Precautions]

WARNING

- When connecting an external device with a CPU module or intelligent function module to modify data of a running programmable controller, configure an interlock circuit in the program to ensure that the entire system will always operate safely. For other forms of control (such as program modification, parameter change, forced output, or operating status change) of a running programmable controller, read the relevant manuals carefully and ensure that the operation is safe before proceeding. Improper operation may damage machines or cause accidents.
 - Especially, when a remote programmable controller is controlled by an external device, immediate action cannot be taken if a problem occurs in the programmable controller due to a communication failure. To prevent this, configure an interlock circuit in the program, and determine corrective actions to be taken between the external device and CPU module in case of a communication failure.
 - Do not write any data to the "system area" and "write-protect area" of the buffer memory in the module. Also, do not use any "use prohibited" signals as an output signal from the CPU module to each module. Doing so may cause malfunction of the programmable controller system. For the "system area", "write-protect area", and the "use prohibited" signals, refer to the user's manual for the module used.
 - If a communication cable is disconnected, the network may be unstable, resulting in a communication failure of multiple stations. Configure an interlock circuit in the program to ensure that the entire system will always operate safely even if communications fail. Failure to do so may result in an accident due to an incorrect output or malfunction.
 - To maintain the safety of the programmable controller system against unauthorized access from external devices via the network, take appropriate measures. To maintain the safety against unauthorized access via the Internet, take measures such as installing a firewall.
-

[Design Precautions]

CAUTION

- Do not install the control lines or communication cables together with the main circuit lines or power cables. Keep a distance of 100mm or more between them. Failure to do so may result in malfunction due to noise.
 - During control of an inductive load such as a lamp, heater, or solenoid valve, a large current (approximately ten times greater than normal) may flow when the output is turned from off to on. Therefore, use a module that has a sufficient current rating.
 - After the CPU module is powered on or is reset, the time taken to enter the RUN status varies depending on the system configuration, parameter settings, and/or program size. Design circuits so that the entire system will always operate safely, regardless of the time.
 - Do not power off the programmable controller or reset the CPU module while the settings are being written. Doing so will make the data in the flash ROM undefined. The values need to be set in the buffer memory and written to the flash ROM again. Doing so also may cause malfunction or failure of the module.
 - When changing the operating status of the CPU module from external devices (such as the remote RUN/STOP functions), select "Do Not Open by Program" for "Opening Method" of "Module Parameter". If "Open by Program" is selected, an execution of the remote STOP function causes the communication line to close. Consequently, the CPU module cannot reopen the line, and external devices cannot execute the remote RUN function.
-

[Installation Precautions]

WARNING

- Shut off the external power supply (all phases) used in the system before mounting or removing the module. Failure to do so may result in electric shock or cause the module to fail or malfunction.
-

[Installation Precautions]

CAUTION

- Use the programmable controller in an environment that meets the general specifications in the Safety Guidelines included with the base unit. Failure to do so may result in electric shock, fire, malfunction, or damage to or deterioration of the product.
 - To mount a module, place the concave part(s) located at the bottom onto the guide(s) of the base unit, and push in the module until the hook(s) located at the top snaps into place. Incorrect interconnection may cause malfunction, failure, or drop of the module.
 - When using the programmable controller in an environment of frequent vibrations, fix the module with a screw.
 - Tighten the screws within the specified torque range. Undertightening can cause drop of the screw, short circuit, or malfunction. Overtightening can damage the screw and/or module, resulting in drop, short circuit, or malfunction.
 - When using an extension cable, connect it to the extension cable connector of the base unit securely. Check the connection for looseness. Poor contact may cause malfunction.
 - When using an SD memory card, fully insert it into the SD memory card slot. Check that it is inserted completely. Poor contact may cause malfunction.
 - Securely insert an extended SRAM cassette or a battery-less option cassette into the cassette connector of the CPU module. After insertion, close the cassette cover and check that the cassette is inserted completely. Poor contact may cause malfunction.
 - Do not directly touch any conductive parts and electronic components of the module, SD memory card, extended SRAM cassette, battery-less option cassette, or connector. Doing so can cause malfunction or failure of the module.
-

[Wiring Precautions]

WARNING

- Shut off the external power supply (all phases) used in the system before installation and wiring. Failure to do so may result in electric shock or cause the module to fail or malfunction.
 - After installation and wiring, attach a blank cover module (RG60) to each empty slot and an included extension connector protective cover to the unused extension cable connector before powering on the system for operation. Failure to do so may result in electric shock.
-

[Wiring Precautions]

CAUTION

- Individually ground the FG and LG terminals of the programmable controller with a ground resistance of 100 ohms or less. Failure to do so may result in electric shock or malfunction.
 - Use applicable solderless terminals and tighten them within the specified torque range. If any spade solderless terminal is used, it may be disconnected when the terminal screw comes loose, resulting in failure.
 - Check the rated voltage and signal layout before wiring to the module, and connect the cables correctly. Connecting a power supply with a different voltage rating or incorrect wiring may cause fire or failure.
 - Connectors for external devices must be crimped or pressed with the tool specified by the manufacturer, or must be correctly soldered. Incomplete connections may cause short circuit, fire, or malfunction.
 - Securely connect the connector to the module. Poor contact may cause malfunction.
 - Do not install the control lines or communication cables together with the main circuit lines or power cables. Keep a distance of 100mm or more between them. Failure to do so may result in malfunction due to noise.
 - Place the cables in a duct or clamp them. If not, dangling cables may swing or inadvertently be pulled, resulting in malfunction or damage to modules or cables.
In addition, the weight of the cables may put stress on modules in an environment of strong vibrations and shocks.
Do not clamp the extension cables with the jacket stripped. Doing so may change the characteristics of the cables, resulting in malfunction.
 - Check the interface type and correctly connect the cable. Incorrect wiring (connecting the cable to an incorrect interface) may cause failure of the module and external device.
 - Tighten the terminal screws or connector screws within the specified torque range. Undertightening can cause drop of the screw, short circuit, fire, or malfunction. Overtightening can damage the screw and/or module, resulting in drop, short circuit, fire, or malfunction.
 - When disconnecting the cable from the module, do not pull the cable by the cable part. For the cable with connector, hold the connector part of the cable. For the cable connected to the terminal block, loosen the terminal screw. Pulling the cable connected to the module may result in malfunction or damage to the module or cable.
 - Prevent foreign matter such as dust or wire chips from entering the module. Such foreign matter can cause a fire, failure, or malfunction.
 - A protective film is attached to the top of the module to prevent foreign matter, such as wire chips, from entering the module during wiring. Do not remove the film during wiring. Remove it for heat dissipation before system operation.
 - Programmable controllers must be installed in control panels. Connect the main power supply to the power supply module in the control panel through a relay terminal block. Wiring and replacement of a power supply module must be performed by qualified maintenance personnel with knowledge of protection against electric shock. For wiring, refer to the MELSEC iQ-R Module Configuration Manual.
 - For Ethernet cables to be used in the system, select the ones that meet the specifications in the user's manual for the module used. If not, normal data transmission is not guaranteed.
-

[Startup and Maintenance Precautions]

WARNING

- Do not touch any terminal while power is on. Doing so will cause electric shock or malfunction.
 - Correctly connect the battery connector. Do not charge, disassemble, heat, short-circuit, solder, or throw the battery into the fire. Also, do not expose it to liquid or strong shock. Doing so will cause the battery to produce heat, explode, ignite, or leak, resulting in injury and fire.
 - Shut off the external power supply (all phases) used in the system before cleaning the module or retightening the terminal screws, connector screws, or module fixing screws. Failure to do so may result in electric shock.
-

[Startup and Maintenance Precautions]

CAUTION

- When connecting an external device with a CPU module or intelligent function module to modify data of a running programmable controller, configure an interlock circuit in the program to ensure that the entire system will always operate safely. For other forms of control (such as program modification, parameter change, forced output, or operating status change) of a running programmable controller, read the relevant manuals carefully and ensure that the operation is safe before proceeding. Improper operation may damage machines or cause accidents.
 - Especially, when a remote programmable controller is controlled by an external device, immediate action cannot be taken if a problem occurs in the programmable controller due to a communication failure. To prevent this, configure an interlock circuit in the program, and determine corrective actions to be taken between the external device and CPU module in case of a communication failure.
 - Do not disassemble or modify the modules. Doing so may cause failure, malfunction, injury, or a fire.
 - Use any radio communication device such as a cellular phone or PHS (Personal Handy-phone System) more than 25cm away in all directions from the programmable controller. Failure to do so may cause malfunction.
 - Shut off the external power supply (all phases) used in the system before mounting or removing the module. Failure to do so may cause the module to fail or malfunction.
 - Tighten the screws within the specified torque range. Undertightening can cause drop of the component or wire, short circuit, or malfunction. Overtightening can damage the screw and/or module, resulting in drop, short circuit, or malfunction.
 - After the first use of the product, do not perform each of the following operations more than 50 times (IEC 61131-2/JIS B 3502 compliant):
Exceeding the limit may cause malfunction.
 - Mounting/removing the module to/from the base unit
 - Inserting/removing the extended SRAM cassette or battery-less option cassette to/from the CPU module
 - Mounting/removing the terminal block to/from the module
 - After the first use of the product, do not insert/remove the SD memory card to/from the CPU module more than 500 times. Exceeding the limit may cause malfunction.
 - Do not touch the metal terminals on the back side of the SD memory card. Doing so may cause malfunction or failure.
 - Do not touch the integrated circuits on the circuit board of an extended SRAM cassette or a battery-less option cassette. Doing so may cause malfunction or failure of the module.
 - Do not drop or apply shock to the battery to be installed in the module. Doing so may damage the battery, causing the battery fluid to leak inside the battery. If the battery is dropped or any shock is applied to it, dispose of it without using.
 - Startup and maintenance of a control panel must be performed by qualified maintenance personnel with knowledge of protection against electric shock. Lock the control panel so that only qualified maintenance personnel can operate it.
 - Before handling the module, touch a conducting object such as a grounded metal to discharge the static electricity from the human body. Failure to do so may cause the module to fail or malfunction.
-

[Operating Precautions]

CAUTION

- When changing data and operating status, and modifying program of the running programmable controller from an external device such as a personal computer connected to an intelligent function module, read relevant manuals carefully and ensure the safety before operation. Incorrect change or modification may cause system malfunction, damage to the machines, or accidents.
 - Do not power off the programmable controller or reset the CPU module while the setting values in the buffer memory are being written to the flash ROM in the module. Doing so will make the data in the flash ROM undefined. The values need to be set in the buffer memory and written to the flash ROM again. Doing so can cause malfunction or failure of the module.
-

[Disposal Precautions]

CAUTION

- When disposing of this product, treat it as industrial waste.
 - When disposing of batteries, separate them from other wastes according to the local regulations. For details on battery regulations in EU member states, refer to the MELSEC iQ-R Module Configuration Manual.
-

[Transportation Precautions]

CAUTION

- When transporting lithium batteries, follow the transportation regulations. For details on the regulated models, refer to the MELSEC iQ-R Module Configuration Manual.
 - The halogens (such as fluorine, chlorine, bromine, and iodine), which are contained in a fumigant used for disinfection and pest control of wood packaging materials, may cause failure of the product. Prevent the entry of fumigant residues into the product or consider other methods (such as heat treatment) instead of fumigation. The disinfection and pest control measures must be applied to unprocessed raw wood.
-

CONDITIONS OF USE FOR THE PRODUCT

(1) Mitsubishi programmable controller ("the PRODUCT") shall be used in conditions;

- i) where any problem, fault or failure occurring in the PRODUCT, if any, shall not lead to any major or serious accident; and
- ii) where the backup and fail-safe function are systematically or automatically provided outside of the PRODUCT for the case of any problem, fault or failure occurring in the PRODUCT.

(2) The PRODUCT has been designed and manufactured for the purpose of being used in general industries.

MITSUBISHI SHALL HAVE NO RESPONSIBILITY OR LIABILITY (INCLUDING, BUT NOT LIMITED TO ANY AND ALL RESPONSIBILITY OR LIABILITY BASED ON CONTRACT, WARRANTY, TORT, PRODUCT LIABILITY) FOR ANY INJURY OR DEATH TO PERSONS OR LOSS OR DAMAGE TO PROPERTY CAUSED BY the PRODUCT THAT ARE OPERATED OR USED IN APPLICATION NOT INTENDED OR EXCLUDED BY INSTRUCTIONS, PRECAUTIONS, OR WARNING CONTAINED IN MITSUBISHI'S USER, INSTRUCTION AND/OR SAFETY MANUALS, TECHNICAL BULLETINS AND GUIDELINES FOR the PRODUCT.

("Prohibited Application")

Prohibited Applications include, but not limited to, the use of the PRODUCT in;

- Nuclear Power Plants and any other power plants operated by Power companies, and/or any other cases in which the public could be affected if any problem or fault occurs in the PRODUCT.
- Railway companies or Public service purposes, and/or any other cases in which establishment of a special quality assurance system is required by the Purchaser or End User.
- Aircraft or Aerospace, Medical applications, Train equipment, transport equipment such as Elevator and Escalator, Incineration and Fuel devices, Vehicles, Manned transportation, Equipment for Recreation and Amusement, and Safety devices, handling of Nuclear or Hazardous Materials or Chemicals, Mining and Drilling, and/or other applications where there is a significant risk of injury to the public or property.

Notwithstanding the above restrictions, Mitsubishi may in its sole discretion, authorize use of the PRODUCT in one or more of the Prohibited Applications, provided that the usage of the PRODUCT is limited only for the specific applications agreed to by Mitsubishi and provided further that no special quality assurance or fail-safe, redundant or other safety features which exceed the general specifications of the PRODUCTS are required. For details, please contact the Mitsubishi representative in your region.

INTRODUCTION

Thank you for purchasing the Mitsubishi Electric MELSEC iQ-R series programmable controllers.

This manual describes the specifications, procedures before operation, wiring, and programming of the relevant products listed below.

Before using this product, please read this manual and the relevant manuals carefully and develop familiarity with the functions and performance of the MELSEC iQ-R series programmable controller to handle the product correctly.

When applying the program examples provided in this manual to an actual system, ensure the applicability and confirm that it will not cause system control problems.

Please make sure that the end users read this manual.



Unless otherwise specified, this manual provides program examples in which the I/O numbers of X/Y0 to X/YF are assigned to the A/D converter module. Assign I/O numbers when applying the program examples to an actual system. For I/O number assignment, refer to the following.

MELSEC iQ-R Module Configuration Manual



Relevant product

R60ADI8-HA

COMPLIANCE WITH EMC AND LOW VOLTAGE DIRECTIVES

Method of ensuring compliance



To ensure that Mitsubishi programmable controllers maintain EMC and Low Voltage Directives when incorporated into other machinery or equipment, certain measures may be necessary. Please refer to one of the following manuals.

-  MELSEC iQ-R Module Configuration Manual
-  Safety Guidelines (This manual is included with the base unit.)

The CE mark on the side of the programmable controller indicates compliance with EMC and Low Voltage Directives.

Additional measures

To ensure that this product maintains EMC and Low Voltage Directives, please refer to one of the following manuals.

-  MELSEC iQ-R Module Configuration Manual
-  Safety Guidelines (This manual is included with the base unit.)

CONTENTS

SAFETY PRECAUTIONS	1
CONDITIONS OF USE FOR THE PRODUCT	9
INTRODUCTION	9
COMPLIANCE WITH EMC AND LOW VOLTAGE DIRECTIVES	10
RELEVANT MANUALS	12
TERMS	13
GENERIC TERM AND ABBREVIATION	13
CHAPTER 1 PART NAMES	14
CHAPTER 2 SPECIFICATIONS	16
2.1 Performance Specifications	16
CHAPTER 3 FUNCTION LIST	18
CHAPTER 4 PROCEDURES BEFORE OPERATION	20
CHAPTER 5 SYSTEM CONFIGURATION	22
CHAPTER 6 WIRING	24
6.1 Wiring Precautions	24
6.2 Terminal Block	24
6.3 External Wiring	27
CHAPTER 7 OPERATION EXAMPLES	31
7.1 Programming Procedure	31
7.2 Program Examples	32
APPENDICES	40
Appendix 1 I/O Conversion Characteristics	40
Appendix 2 Accuracy	42
Appendix 3 External Dimensions	43
INDEX	44
REVISIONS	46
WARRANTY	47
TRADEMARKS	48

RELEVANT MANUALS

Manual name [manual number]	Description	Available form
MELSEC iQ-R HART-Enabled Analog-Digital Converter Module User's Manual (Startup) [SH-082047ENG] (this manual)	System configuration, specifications, procedures before operation, wiring, and operation examples of the HART-enabled analog-digital converter module	Print book e-Manual PDF
MELSEC iQ-R HART-Enabled Analog-Digital Converter Module User's Manual (Application) [SH-082048ENG]	Functions, parameter settings, I/O signals, buffer memory, and troubleshooting of the HART-enabled analog-digital converter module	Print book e-Manual PDF
MELSEC iQ-R Programming Manual (CPU Module Instructions, Standard Functions/Function Blocks) [SH-081266ENG]	Instructions and standard functions/function blocks for the CPU module	e-Manual PDF

This manual does not include detailed information on the following:

- General specifications
- Applicable CPU modules and the number of mountable modules
- Installation

For details, refer to the following.

 MELSEC iQ-R Module Configuration Manual

This manual does not include information on the module function blocks.

For details, refer to the Function Block Reference for the module used.

Point

e-Manual refers to the Mitsubishi FA electronic book manuals that can be browsed using a dedicated tool.

e-Manual has the following features:

- Required information can be cross-searched in multiple manuals.
- Other manuals can be accessed from the links in the manual.
- The hardware specifications of each part can be found from the product figures.
- Pages that users often browse can be bookmarked.
- Sample programs can be copied to an engineering tool.

TERMS

Unless otherwise specified, this manual uses the following terms.

Term	Description
Buffer memory areas	A memory in an intelligent function module for storing data such as setting values and monitored values. For the CPU module, this term refers to a memory for storing data such as setting values and monitored values of the Ethernet function and data used for data communication of the multiple CPU system function.
CommDTM (Communication DTM)	A software module to configure settings for communication with field devices from a personal computer via the HART master
Device DTM	A software module to configure parameter settings and perform monitoring of field devices
DTM (Device Type Manager)	A software module to configure communication settings and parameter settings of field devices and monitor field devices when the FDT frame application is used
Engineering tool	A tool that is used to configure settings of a programmable controller and perform programming, debug, and maintenance of a programmable controller
FDT (Field Device Tool)	Software standards for control, maintenance, adjustment, and engineering of field devices
FDT frame application	An application for using DTM that complies with the open standards for FDT/DTM
Global label	A label that is valid for all the program data when multiple program data are created in the project. The global label has two types: a module specific label (module label), which is generated automatically by GX Works3, and an optional label, which can be created for any specified device.
MELSOFT FieldDeviceConfigurator	Field device control and setting software manufactured by Mitsubishi Electric that is compliant with the open standards for FDT/DTM. As FDT frame application, this software enables users to configure parameter settings of field devices and perform maintenance and adjustment of field devices.
Module label	A label that represents one of memory areas (I/O signals and buffer memory areas) specific to each module in a given character string. For the module used, GX Works3 automatically generates this label, which can be used as a global label.
Watchdog timer error	A timer that enables the module to monitor whether its own internal processing is normal. A watch dog timer error is an error that occurs if the internal processing of the A/D converter module is abnormal.

GENERIC TERM AND ABBREVIATION

Unless otherwise specified, this manual uses the following generic terms and abbreviations.

Generic term and abbreviation	Description
A/D converter module	An abbreviation for MELSEC iQ-R HART-enabled analog-digital converter module

1 PART NAMES

This chapter describes the part names of the A/D converter module.

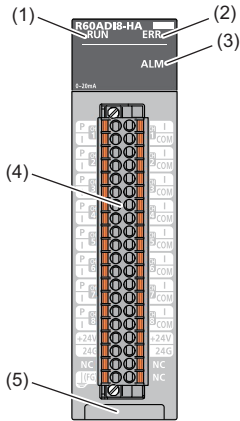

No.	Name	Description
(1)	RUN LED	Indicates the operating status of the module. On: Normal operation Flashing (400ms cycles): Selected as a module for the online module change Off: 5V power supply interrupted, watchdog timer error occurred, or module replacement allowed in the process of the online module change
(2)	ERR LED	Indicates the error status of the module.*1 On: Error occurred Off: Normal operation
(3)	ALM LED	Indicates the alarm status of the module.*1 On: Warning (process alarm or rate alarm) issued Flashing: Input signal error detected Off: Normal operation
(4)	Terminal block	40-point spring clamp terminal block for connecting input signal wires of external devices and others
(5)	Production information marking	Shows the production information (16 digits) of the module.

*1 For details, refer to the following.

📖 MELSEC iQ-R HART-Enabled Analog-Digital Converter Module User's Manual (Application)

2 SPECIFICATIONS

This chapter describes the performance specifications.

2.1 Performance Specifications

This section describes the performance specifications of the A/D converter module.

Item		Specifications		
Number of analog input channels		8 channels		
Analog input current		0 to 20mADC (input resistance: 250Ω)		
Power supply part for external devices	Maximum supply current	DC24mA		
	Short-circuit protection	Provided (limiting current: 25 to 40mA)		
Digital output		16-bit signed binary value (-32768 to 32767)		
I/O characteristics, resolution*1		Analog current input range	Digital output value	Resolution
		0 to 20mA	0 to 32000	625.0nA
		4 to 20mA		500.0nA
		4 to 20mA (extended mode)	-8000 to 32000	500.0nA
Accuracy (accuracy of the maximum digital output value)*2	Ambient temperature 25±5°C	Within ±0.1% (±32 digits)		
	Ambient temperature 0 to 55°C	Within ±0.3% (±96 digits)		
Response time*3		400ms		
Sampling cycle		80ms/8CH		
Absolute maximum input		Current: 30mA*4		
Isolation method		Between I/O terminals and programmable controller power supply: Photocoupler Between input channels: Non-isolation		
Withstand voltage		Between I/O terminals and programmable controller power supply: 500VACrms for 1 minute		
Isolation resistance		Between I/O terminals and programmable controller power supply: 10MΩ or higher, at 500VDC		
HART® modem		FSK physical layer (multiplexed)		
HART® communication function		Protocol revision 7 supported 4 process variables supported FDT/DTM supported		
Number of occupied I/O points		16 points (I/O assignment: Intelligent 16 points)		
External interface		40-point two-piece spring clamp terminal block (push-in type)		
Applicable wire size		Stranded wire: 0.5 to 1.5mm ² (24 to 16 AWG), terminal slot size: 2.4mm × 1.5mm		
Applicable solderless terminal		AI0.5-10WH (PHOENIX CONTACT GmbH & Co. KG), applicable wire size: 0.5mm ² AI0.75-10GY (PHOENIX CONTACT GmbH & Co. KG), applicable wire size: 0.75mm ² A1-10 (PHOENIX CONTACT GmbH & Co. KG), applicable wire size: 1.0mm ² A1.5-10 (PHOENIX CONTACT GmbH & Co. KG), applicable wire size: 1.5mm ²		
External power supply		24VDC +20%, -15%*5		
		Ripple, spike: 500mV _{P-P} or lower		
		Inrush current: 6.2A, 430μs or less		
		Current consumption: 0.22A		
Internal current consumption (5VDC)		0.17A		
External dimensions	Height	106mm (base unit mounting side: 98mm)		
	Width	27.8mm		
	Depth	125mm		
Weight		0.21kg		

*1 For details on the I/O conversion characteristics, refer to the following.

☞ Page 40 I/O Conversion Characteristics

*2 Except for the conditions under noise influence.

*3 The time until an analog input signal reaches the A/D converter in the A/D converter module.

*4 This current value is an instantaneous value at which no breakdown occurs in the internal resistance of the module.

*5 Consider voltage drop between the external power supply and the HART-enabled device when supplying the power to the HART-enabled device from the A/D converter module. (☞ Page 30 Precautions on voltage drop)

3 FUNCTION LIST

The following table lists the functions of the A/D converter module. For details on the functions, refer to the following.
 MELSEC iQ-R HART-Enabled Analog-Digital Converter Module User's Manual (Application)

Item		Description	
Range switching function		Allows switching the input range of an analog input for each channel. Switching the range makes it possible to change the I/O conversion characteristics.	
HART communication function		Enables the A/D converter module to communicate with HART-enabled external devices as the master module. In addition, using FDT application and DTM allows the user to set up the external devices via the A/D converter module.	
A/D conversion enable/disable setting function		Controls whether to enable or disable the A/D conversion for each channel.	
A/D conversion method	Sampling processing	Converts analog input values every sampling cycle and stores them as digital output values in the buffer memory areas.	
	Averaging processing	Time average	Executes A/D conversion for a set time, and averages the total value excluding the maximum value and the minimum value. The average value is stored in the buffer memory area.
		Count average	Executes A/D conversion for a set number of times, and averages the total value excluding the maximum value and the minimum value. The average value is stored in the buffer memory area.
		Moving average	Averages digital output values taken every sampling cycle for a specified number of times, and stores the average value in the buffer memory area. Because the target range for averaging processing is moved in response to every sampling processing, the latest digital output value can be obtained.
Primary delay filter		Smooths the transient noise of analog input according to the set time constant. The smoothed digital output value is stored in the buffer memory area.	
Scaling function		Performs scale conversion on digital output values within a specified range between a scaling lower limit value and a scaling upper limit value. This function reduces the time and effort to create a program of the scale conversion.	
Maximum value/minimum value hold function		Stores the maximum and minimum values of digital operation values to the buffer memory areas for each channel.	
Warning output function	Process alarm	Outputs a warning when a digital operation value enters the preset warning output range.	
	Rate alarm	Outputs a warning when the change rate of a digital output value is equal to or larger than the rate alarm upper limit value, or the rate is equal to or smaller than the rate alarm lower limit value.	
Input signal error detection function		Detects an analog input value that is equal to, larger, or smaller than the set values.	
Interrupt function		Executes an interrupt program of the CPU module when an interrupt factor such as an input signal error or warning output is detected.	
Error history function		Records up to the 16 errors and alarms that occurred in the A/D converter module to store them into the buffer memory areas.	
Event history function		Collects the errors and alarms that occurred and the operations executed in the A/D converter module as event information into the CPU module.	
Online module change		Allows module replacement without stopping the system. For the procedure of the online module change, refer to the following.  MELSEC iQ-R Online Module Change Manual	

4 PROCEDURES BEFORE OPERATION

This chapter describes the procedures before operation.

1. Mounting a module

Mount the A/D converter module in any desired configuration.

2. Wiring

Perform wiring of external devices to the A/D converter module.

 Page 24 WIRING

3. Adding a module

Add the A/D converter module to a module configuration by using the engineering tool. For details, refer to the following.

 GX Works3 Operating Manual

4. Parameter setting

Set the parameters of the A/D converter module by using the engineering tool. For details, refer to the following.

 MELSEC iQ-R HART-Enabled Analog-Digital Converter Module User's Manual (Application)

5. Programming

Create a program. For details, refer to the following.

 Page 31 OPERATION EXAMPLES

6. HART-enabled device setting

To use the HART communication function, configure the settings of the HART-enabled device using CommDTM for the R60ADI8-HA. For details, refer to the following.

 MELSEC iQ-R HART-Enabled Analog-Digital Converter Module User's Manual (Application)

5 SYSTEM CONFIGURATION

For the system configuration of the MELSEC iQ-R series, CPU modules that can use A/D converter module, and the number of mountable modules, refer to the following.

 MELSEC iQ-R Module Configuration Manual

6 WIRING

This chapter describes the wiring of the A/D converter module.

6.1 Wiring Precautions

- Check the signal layout before performing wiring to the A/D converter module, and connect the cables correctly. For the signal layout, refer to the following.

☞ Page 24 Signal names of the terminal block

- Establish a single-point ground for the shield of the shield wire or the shielded cable.
- Tighten the module fixing screws and other screws within the specified torque range.

Screw type	Tightening torque range
Module fixing screw (M3) ^{*1}	0.37 to 0.48N·m
Terminal block mounting screw (M2)	0.1 to 0.2N·m

*1 The hook on the top of the module allows the module to be fixed to a base unit easily. In a place where vibrations frequently occur, however, use of module fixing screws is recommended.

- Use bar solderless terminals for wiring to the terminal block. If a stripped wire is inserted into a wire insertion opening, the wire cannot be securely clamped.
- For the wire strip length, follow the specifications of the bar solderless terminal used. To attach a bar solderless terminal to a wire, use a crimping tool.

6.2 Terminal Block

Signal names of the terminal block

The following table shows signal names of the terminal block.

Terminal block	Terminal number	Signal name	Terminal number	Signal name
	1	CH1 P	21	CH1 I
	2	CH1 I	22	CH1 COM
	3	CH2 P	23	CH2 I
	4	CH2 I	24	CH2 COM
	5	CH3 P	25	CH3 I
	6	CH3 I	26	CH3 COM
	7	CH4 P	27	CH4 I
	8	CH4 I	28	CH4 COM
	9	CH5 P	29	CH5 I
	10	CH5 I	30	CH5 COM
	11	CH6 P	31	CH6 I
	12	CH6 I	32	CH6 COM
	13	CH7 P	33	CH7 I
	14	CH7 I	34	CH7 COM
	15	CH8 P	35	CH8 I
	16	CH8 I	36	CH8 COM
	17	+24V	37	+24V
	18	24G	38	24G
	19	NC	39	NC
	20	FG	40	NC

Removing the terminal block

The following shows the procedure to remove the terminal block.

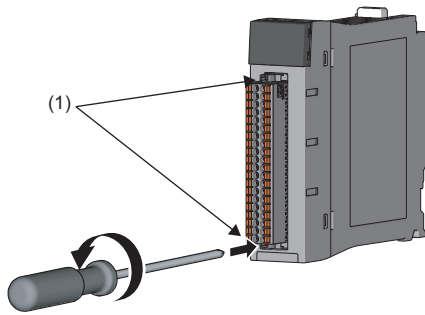

1. Loosen two terminal block mounting screws attached on the upper and lower parts of the terminal block (shown as (1)).

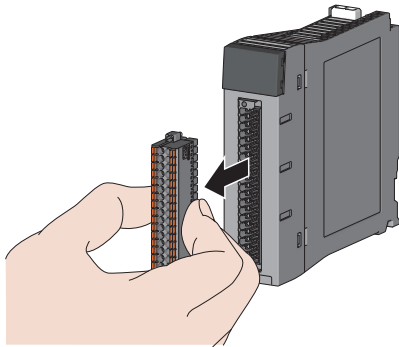

2. Remove the terminal block.

Mounting the terminal block

To mount the terminal block, attach the terminal block, and tighten two terminal block mounting screws to the upper and lower parts of the terminal block.

List of bar solderless terminals

The following table lists recommended bar solderless terminals.

Product		Model	Applicable wire size	Wire strip length	Contact
Bar solderless terminal	With insulation sleeve	A10.5-10WH	0.5mm ²	13mm	PHOENIX CONTACT GmbH & Co. KG www.phoenixcontact.co.jp
		A10.75-10GY	0.75mm ²	13mm	
	Without insulation sleeve	A1-10	1.0mm ²	10mm	
		A1.5-10	1.5mm ²	10mm	
Bar solderless terminal tool		CRIMPFOX6	—		

Processing method of the cable terminal

Strip the cable from the tip to connect a bar solderless terminal at the stripped area. For the cable strip length, follow the specifications of the bar solderless terminal used. Stripping the cable too long cause the conductive part to stick out of the terminal block, increasing the risk of electric shock or short circuit between adjacent terminals. Stripping the cable too short may cause a poor contact to the spring clamp terminal part.

Connecting a cable

Insert a wire with a bar solderless terminal into the wire insertion opening and push it in. Then, pull the wire lightly and check that it is clamped securely.

Use the bar solderless terminal of the correct size and in the correct orientation. Incorrect size or orientation may cause the inserted terminal to stick in or the terminal block to be damaged. When using a bar solderless terminal other than the recommended ones, the dimensions of the cross-sectional surface of the after-processed terminal (including processing errors) should be smaller than those shown below. For the correct terminal orientation, refer to the figure below.

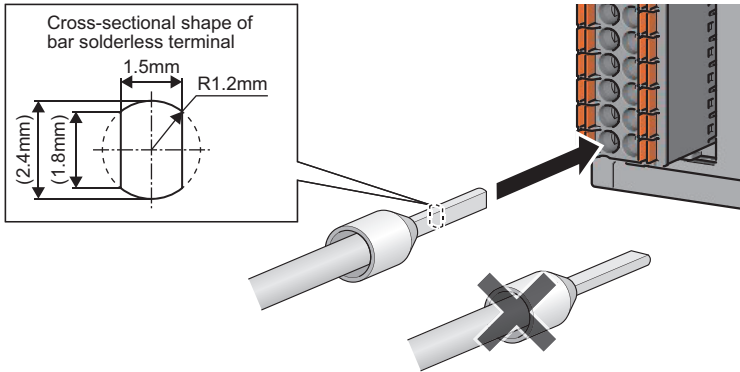

Disconnecting a cable

Push the open/close button for the wire to be disconnected with a flathead screwdriver. Pull out the wire with the open/close button pushed in.

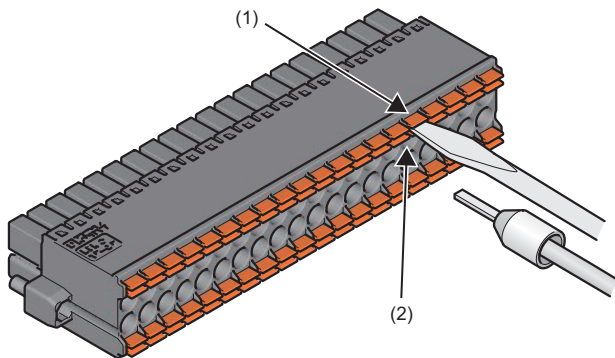

- (1) Open/close button
- (2) Wire insertion opening

6.3 External Wiring

Wiring to the terminal block

The following figures show wiring to the terminal block. The connection destination terminal varies depending on the external device to be connected.

■Wiring of the external power supply

To operate the A/D converter module irrespective of the external power supply to be connected, 24VDC external power needs to be supplied to the A/D converter module. Supply 24VDC to either right +24V terminal and 24G terminal of the A/D converter module.

■When 24VDC is not supplied from the A/D converter module to the external device

For the channel that does not supply 24VDC from the A/D converter module to the external device, connect the external device to either right CH□ I terminal and CH□ COM terminal.

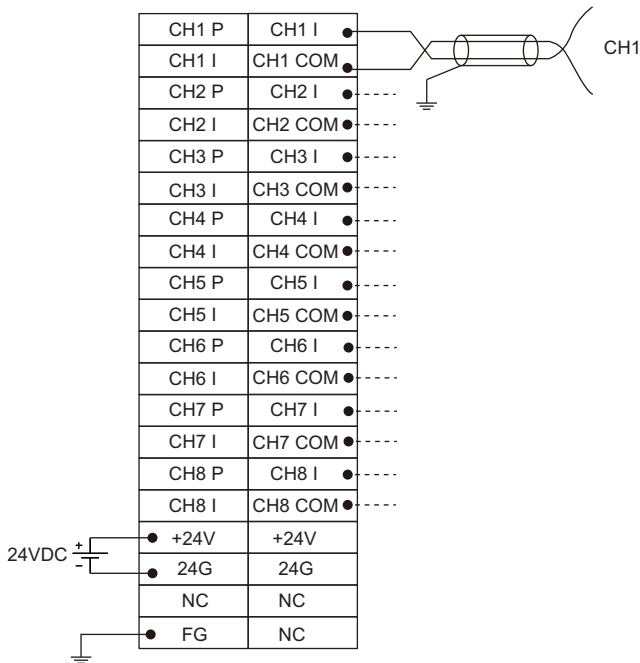

■When power is supplied from the A/D converter module to the external device

For the channel that supplies power from the A/D converter module to the external device to be connected, connect the external device to CH□ P terminal and either right CH□ I terminal.

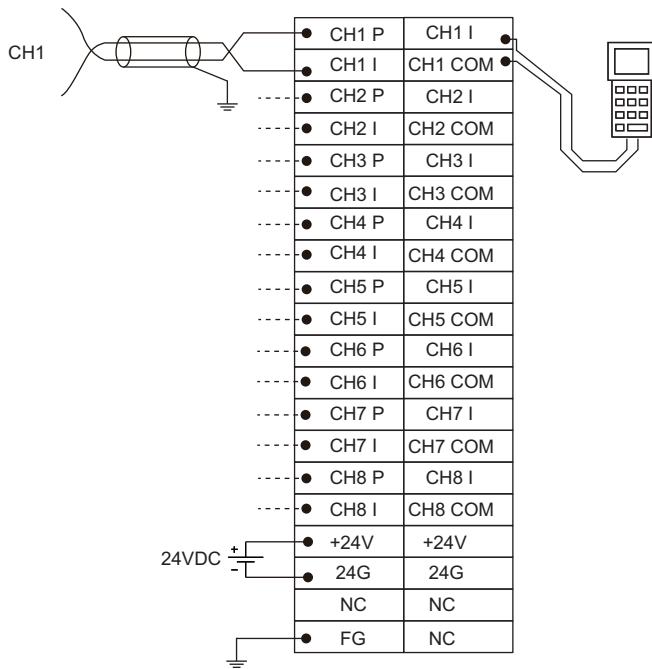

Point

- To use HART communication function, connect only one HART-enabled device per channel. Do not connect multiple HART-enabled devices to one channel. In addition, do not connect one HART-enabled device to multiple channels.
- Turn on the external power supply first, then the programmable controller system.

External wiring examples

The following figures show the examples of external wiring.

- When 24VDC is not supplied from the A/D converter module to the external device

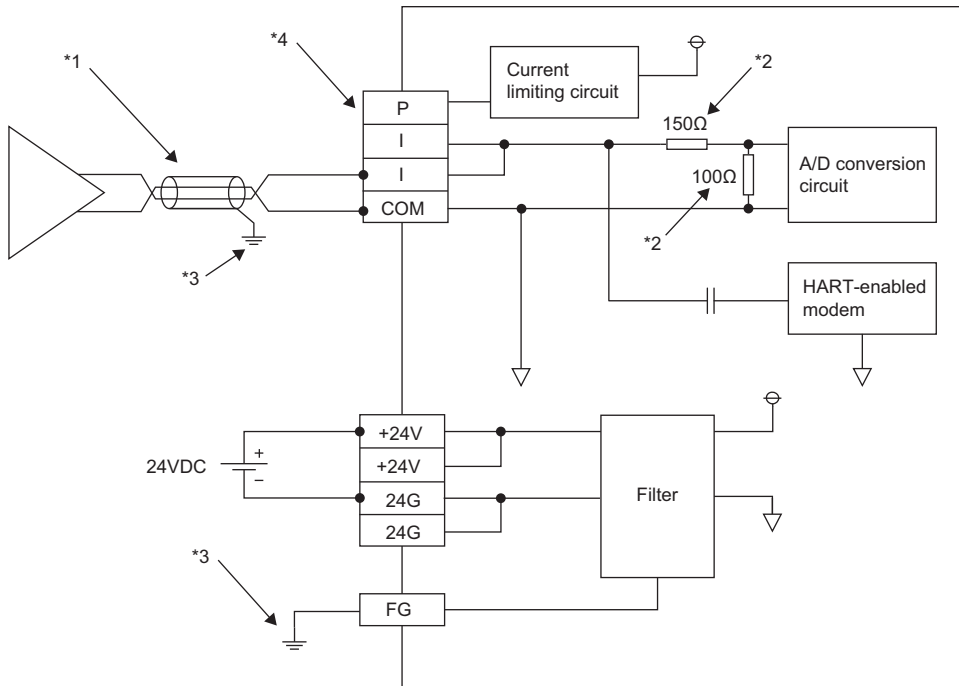

- When power is supplied from the A/D converter module to the external device

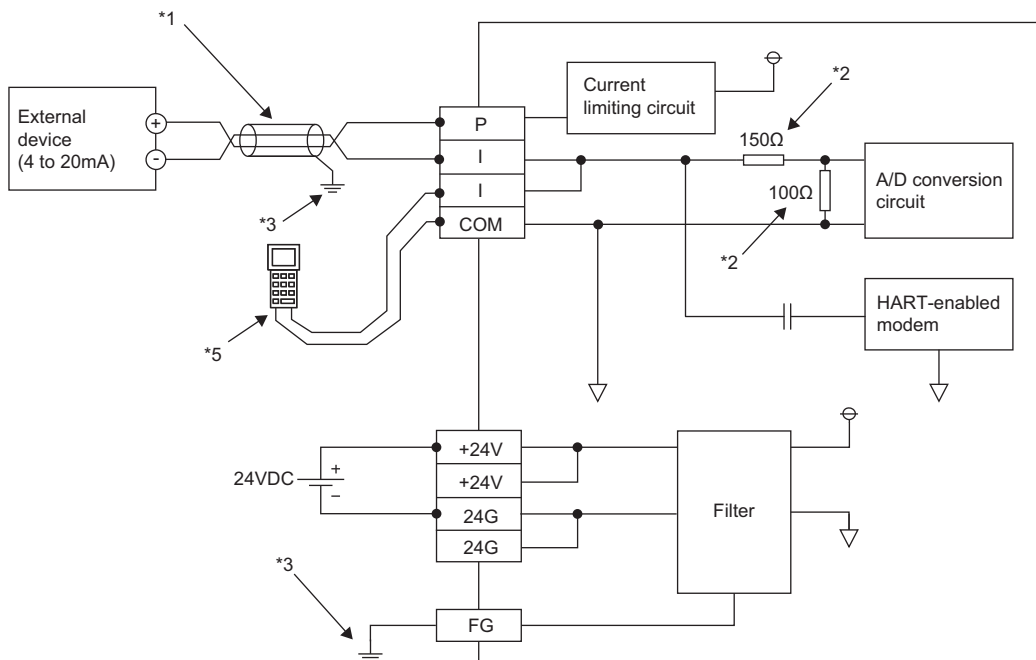

- *1 Use 2-core twisted cable.
- *2 Input resistance of the A/D converter module.
- *3 Be sure to ground the shield wire of cables on each channel and the FG terminal.
- *4 Be sure to open the CH \square P terminal because the power supply for the external device is always on.
- *5 To use HART handheld computer or similar device, connect it to CH \square I terminal and CH \square COM terminal.

Point

- Ground also the FG terminal of the power supply module.
- To ground the external power supply, establish a ground on the 24G side. When the +24V side is grounded, the module may fail. Therefore, attach an insulation filter between the A/D converter module and the external power supply.

Precautions on voltage drop

When the external device is supplied with power from the A/D converter module, care needs to be taken for the voltage drop across the external power supply and the external device.

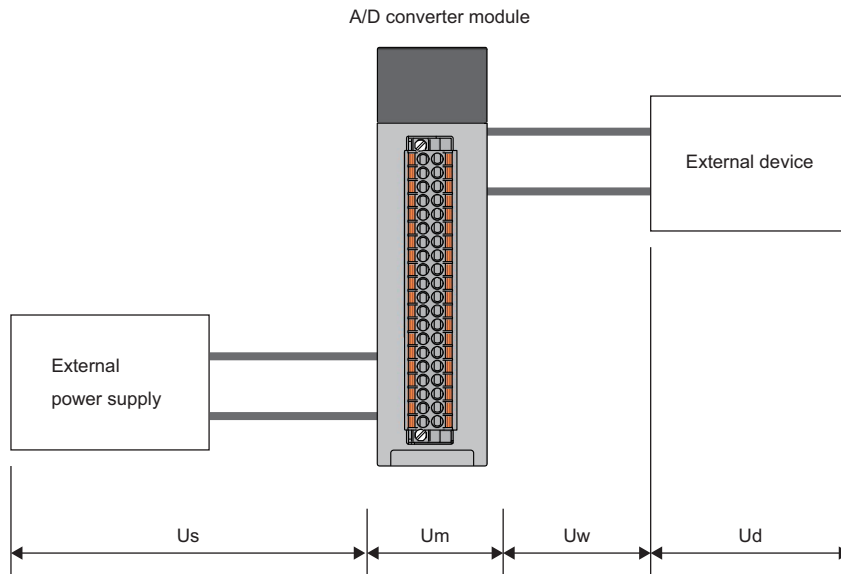

U_s : Input voltage by external power supply

U_m : Voltage drop by A/D converter module (maximum 9.18V)

U_w : Voltage drop of wiring (total cable length \times (cable resistance/m) \times maximum current)

U_d : Required voltage for operating external device (Refer to the manual of the external device used.)

To properly operate the A/D converter module and the external device, satisfy the following condition for the input voltage of the external power supply.

- $U_s \geq U_m + U_w + U_d$

7 OPERATION EXAMPLES

This chapter describes the programming procedure and the basic program of the A/D converter module.

7.1 Programming Procedure

Take the following steps to create a program for running the A/D converter module:

1. Set parameters.

 Page 33 Parameter settings

2. Create a program.

 Page 36 Program Examples

Point

Using function blocks (FBs) reduces load at programming and improves the readability of programs. For details on the function blocks, refer to the following.

 MELSEC iQ-R Analog-Digital Converter Module/Digital-Analog Converter Module Function Block Reference

7.2 Program Examples

System configuration

The following figure shows an example of the system configuration.

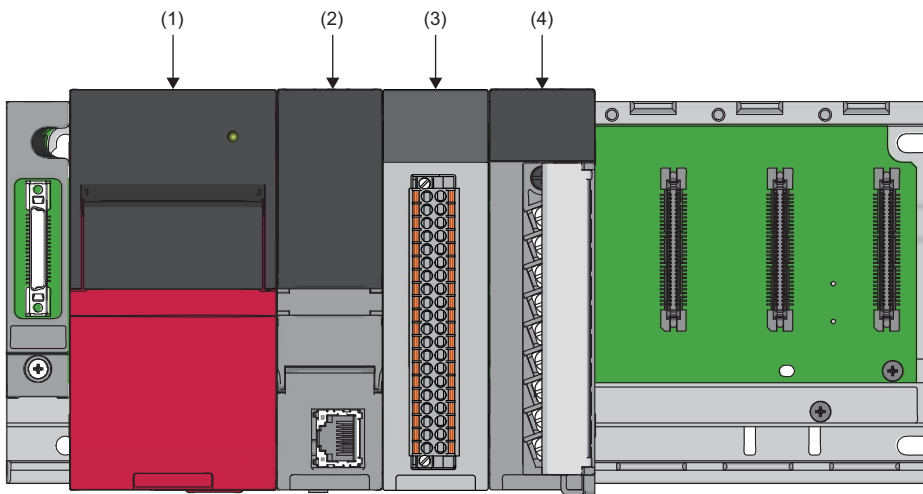

- (1) Power supply module (R61P)
- (2) CPU module (R04CPU)
- (3) A/D converter module (R60ADI8-HA)
- (4) Input module (RX10)

Conditions in the program

- This program reads digital output values or digital operation values from CH1 to CH4 of the A/D converter module where A/D conversion is enabled. HART device variables of CH2 and CH4 are also read from the HART-enabled device using the HART communication function.
- The A/D conversion takes place in CH1 and CH4 by means of sampling processing; in CH2 by means of averaging processing for 10 samples; and in CH3 by means of moving average for 10 samples.

Parameter settings

Configure initial settings in the module parameter of the engineering tool. The auto refresh setting does not need to be changed here.

For details on the parameter settings, refer to the following.

 MELSEC iQ-R HART-Enabled Analog-Digital Converter Module User's Manual (Application)

Function	Setting item	CH1 setting value	CH2 setting value	CH3 setting value	CH4 setting value
Input range switching function	Input range setting	0 to 20mA	4 to 20mA	0 to 20mA	4 to 20mA
A/D conversion enable/disable setting function	A/D conversion enable/disable setting	A/D conversion enable	A/D conversion enable	A/D conversion enable	A/D conversion enable
A/D conversion method	Averaging process specification	Sampling processing	Count average	Moving average	Sampling processing
	Time average/Count average/Moving average/Primary delay filter constant setting	—	10 times	10 times	—
HART communication function	HART communication enable/disable setting	Disable	Enable	Disable	Enable
	HART maximum retries setting	—	3	—	3
Scaling settings	Scaling enable/disable setting	—	—	Enable	—
	Scaling upper limit value	—	—	16000	—
	Scaling lower limit value	—	—	2000	—
Warning output function (Process alarm)	Warning output setting (Process alarm)	Disable	Enable	Disable	Disable
	Process alarm upper upper limit value	—	32000	—	—
	Process alarm upper lower limit value	—	28000	—	—
	Process alarm lower upper limit value	—	4000	—	—
	Process alarm lower lower limit value	—	0	—	—
Warning output function (Rate alarm)	Warning output setting (Rate alarm)	Enable	Disable	Disable	Disable
	Rate alarm warning detection cycle setting	10 times	—	—	—
	Rate alarm upper limit value	25.0%	—	—	—
	Rate alarm lower limit value	-5.0%	—	—	—
Input signal error detection function	Input signal error detection setting	Upper limit detection	Disable	Disable	Disable
	Input signal error detection setting value	10.0%	—	—	—

- Set default values for the parameters other than the above.
- Set default values for the parameters of CH5 to CH8.

Label settings

GX Works3 provides functions that support the creation of a program.

The following table lists the module labels and global labels used for the program examples in this section.

There is no need to change the settings of the module labels. For details on the global labels, refer to the following.

 MELSEC iQ-R Programming Manual (Program Design)

Classification	Label name	Description	Device
Module label	R60ADHART_1.bModuleREADY	Module READY	X0
	R60ADHART_1.bExternalPowerSupplyREADY_Flag	External power supply READY flag	X7
	R60ADHART_1.bInputSignalErrorDetectionSignal	Input signal error detection signal	X0C
	R60ADHART_1.bMaxValueMinValueResetCompletedFlag	Maximum value/minimum value reset completed flag	X0D
	R60ADHART_1.bA_D_conversionCompletedFlag	A/D conversion completed flag	X0E
	R60ADHART_1.bErrorFlag	Error flag	X0F
	R60ADHART_1.bOperatingConditionSettingRequest	Operating condition setting request	Y9
	R60ADHART_1.bMaxValueMinValueResetRequest	Maximum value/minimum value reset request	Y0D
	R60ADHART_1.stnMonitor[0].wDigitalOutputValue	CH1 Digital output value	—
	R60ADHART_1.uA_D_conversionCompletedFlag.0	CH1 A/D conversion completed flag	—
	R60ADHART_1.stnMonitor[1].wDigitalOutputValue	CH2 Digital output value	—
	R60ADHART_1.uA_D_conversionCompletedFlag.1	CH2 A/D conversion completed flag	—
	R60ADHART_1.stnMonitor[2].wDigitalOperationValue	CH3 Digital operation value	—
	R60ADHART_1.uA_D_conversionCompletedFlag.2	CH3 A/D conversion completed flag	—
	R60ADHART_1.stnMonitor[3].wDigitalOutputValue	CH4 Digital output value	—
	R60ADHART_1.uA_D_conversionCompletedFlag.3	CH4 A/D conversion completed flag	—
	R60ADHART_1.stnMonitor[2].wMaxValue	CH3 Maximum value	—
	R60ADHART_1.stnMonitor[2].wMinValue	CH3 Minimum value	—
	R60ADHART_1.uWarningOutputFlagProcessAlarmUpperLimit.1	CH2 Warning output flag (Process alarm upper limit)	—
	R60ADHART_1.uWarningOutputFlagProcessAlarmLowerLimit.1	CH2 Warning output flag (Process alarm lower limit)	—
	R60ADHART_1.uWarningOutputFlagRateAlarmUpperLimit.0	CH1 Warning output flag (Rate alarm upper limit)	—
	R60ADHART_1.uWarningOutputFlagRateAlarmLowerLimit.0	CH1 Warning output flag (Rate alarm lower limit)	—
	R60ADHART_1.uInputSignalErrorDetectionFlag.0	CH1 Input signal error detection flag	—
	R60ADHART_1.stHART.uScanList.1	CH2 HART scan list	—
	R60ADHART_1.stHART.stnDevice[1].ePrimaryValue	CH2 PV value	—
	R60ADHART_1.stHART.stnDevice[1].eSecondaryValue	CH2 SV value	—
	R60ADHART_1.stHART.stnDevice[1].eTertiaryValue	CH2 TV value	—
	R60ADHART_1.stHART.stnDevice[1].eQuaternaryValue	CH2 QV value	—
	R60ADHART_1.stHART.uScanList.3	CH4 HART scan list	—
	R60ADHART_1.stHART.stnDevice[3].ePrimaryValue	CH4 PV value	—
	R60ADHART_1.stHART.stnDevice[3].eSecondaryValue	CH4 SV value	—

Classification	Label name	Description	Device
Labels to be defined	Define global labels as shown below:		
	Label Name	Data Type	Class Assign (Device/Label)
1	CH1_DigOutValTempArea	Word [Signed]	VAR_GLOBAL D11
2	CH2_DigOutValTempArea	Word [Signed]	VAR_GLOBAL D12
3	CH3_DigCalcValTempArea	Word [Signed]	VAR_GLOBAL D13
4	CH4_DigOutValTempArea	Word [Signed]	VAR_GLOBAL D14
5	CH3_DigMaxValTempArea	Word [Signed]	VAR_GLOBAL D15
6	CH3_DigMinValTempArea	Word [Signed]	VAR_GLOBAL D16
7	DigOutValSig	Bit	VAR_GLOBAL X10
8	MaxMinReadSig	Bit	VAR_GLOBAL X11
9	MaxMinResetSig	Bit	VAR_GLOBAL X12
10	CH2_ProcAlmUpLimit	Bit	VAR_GLOBAL F0
11	CH2_ProcAlmLowLimit	Bit	VAR_GLOBAL F1
12	CH1_RateAlmUpLimit	Bit	VAR_GLOBAL F2
13	CH1_RateAlmLowLimit	Bit	VAR_GLOBAL F3
14	CH1_InputSigErr	Bit	VAR_GLOBAL F4
15	ErrResetSig	Bit	VAR_GLOBAL X13
16	ErrOperationEN	Bit	VAR_GLOBAL
17	ErrOperationENO	Bit	VAR_GLOBAL
18	ErrOperationOK	Bit	VAR_GLOBAL
19	UnitErrFlg	Bit	VAR_GLOBAL
20	UnitErrCode	Word [Unsigned]/Bit String [16-bit]	VAR_GLOBAL
21	UnitAlarmCode	Word [Unsigned]/Bit String [16-bit]	VAR_GLOBAL
22	eCH2_ProcessVariable_PV	FLOAT [Single Precision]	VAR_GLOBAL D20
23	eCH2_ProcessVariable_SV	FLOAT [Single Precision]	VAR_GLOBAL D22
24	eCH2_ProcessVariable_TV	FLOAT [Single Precision]	VAR_GLOBAL D24
25	eCH2_ProcessVariable_QV	FLOAT [Single Precision]	VAR_GLOBAL D26
26	eCH4_ProcessVariable_PV	FLOAT [Single Precision]	VAR_GLOBAL D28
27	eCH4_ProcessVariable_SV	FLOAT [Single Precision]	VAR_GLOBAL D30

Program Examples

Program example 1

The following figure shows an example of the program to read digital output values of CH1, CH2, and CH4 and digital operation values of CH3 and save them.

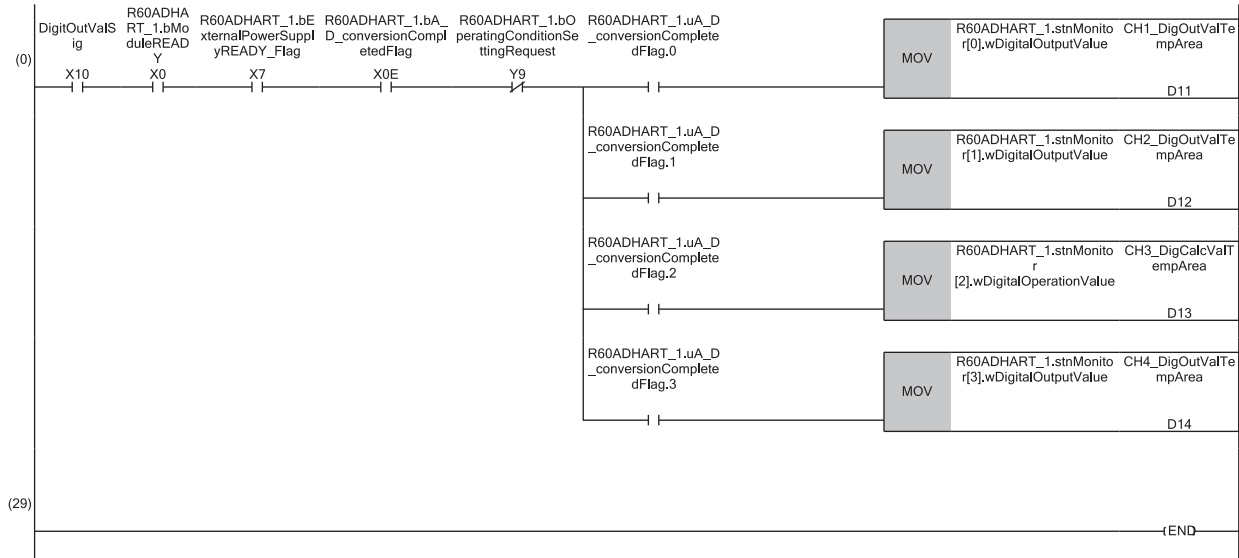

(0) CH1 Digital output value, CH2 Digital output value, CH3 Digital operation value, and CH4 Digital output value are to be read.

Program example 2

This program is an example to read the maximum and minimum values of CH3, which in turn are cleared.

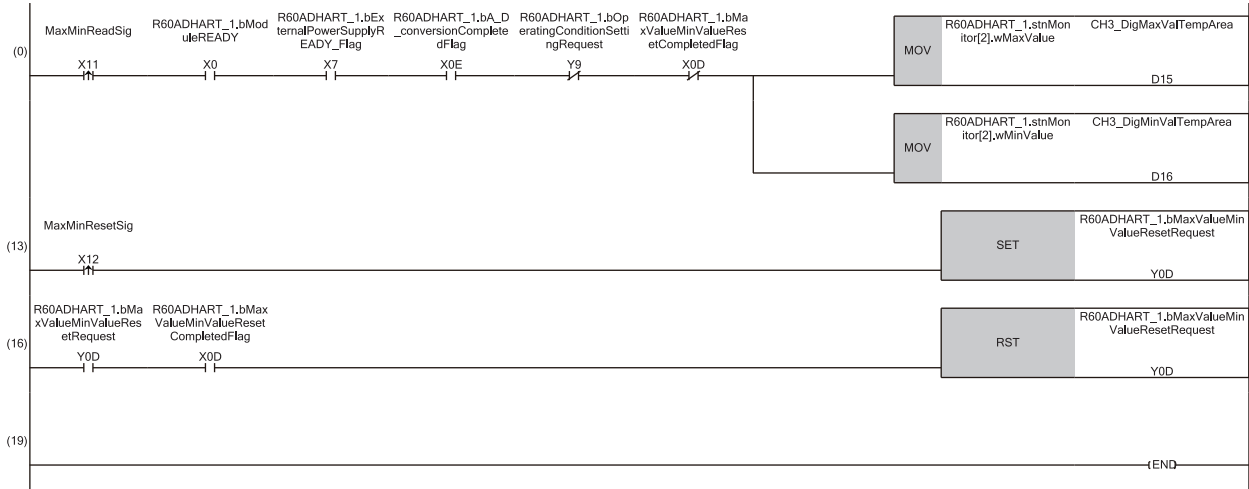

(0) CH3 Maximum value and CH3 Minimum value are to be read.

(13)'Maximum value/minimum value reset request' (YD) is to be turned on.

(16)'Maximum value/minimum value reset request' (YD) is to be turned off.

■Program example 3

This program is an example to perform the processing at the time when a process alarm upper/lower limit warning is issued in CH2.

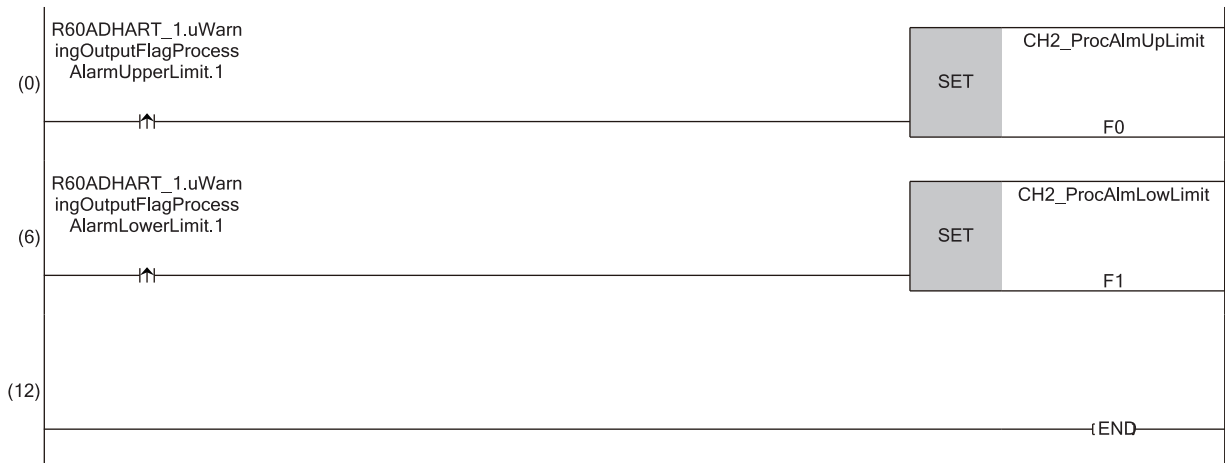

(0) The processing at the time when a process alarm upper limit warning is issued in CH2 is to be performed.

(6) The processing at the time when a process alarm lower limit warning is issued in CH2 is to be performed.

■Program example 4

This program is an example to perform the processing at the time when a rate alarm upper/lower limit warning is issued in CH1.

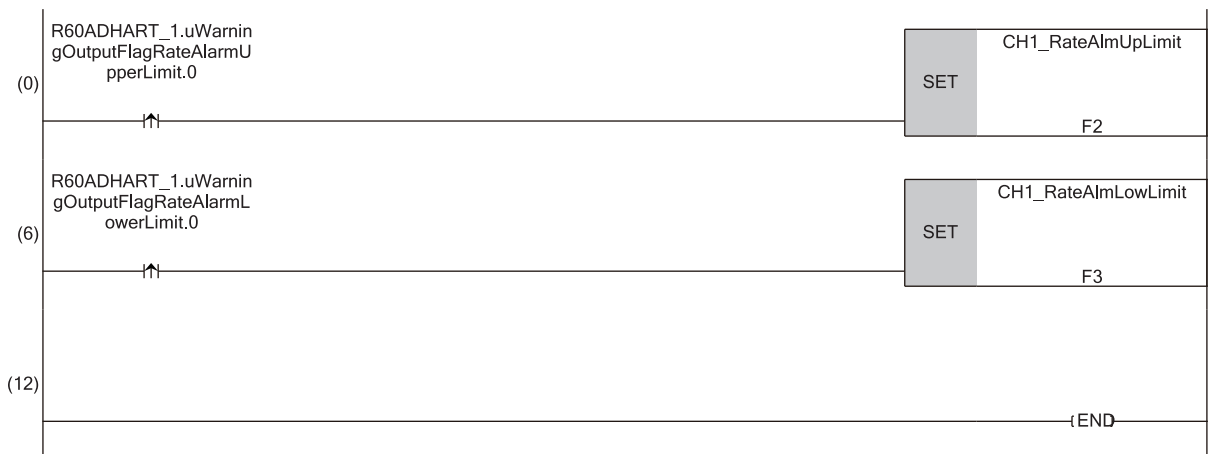

(0) Performs a processing of when a warning (rate alarm upper limit) has occurred in CH1.

(6) Performs a processing of when a warning (rate alarm lower limit) has occurred in CH1.

Program example 5

This program is an example where after the processing of an input signal error of CH1, Input signal error detection flag and the stored error code are cleared.

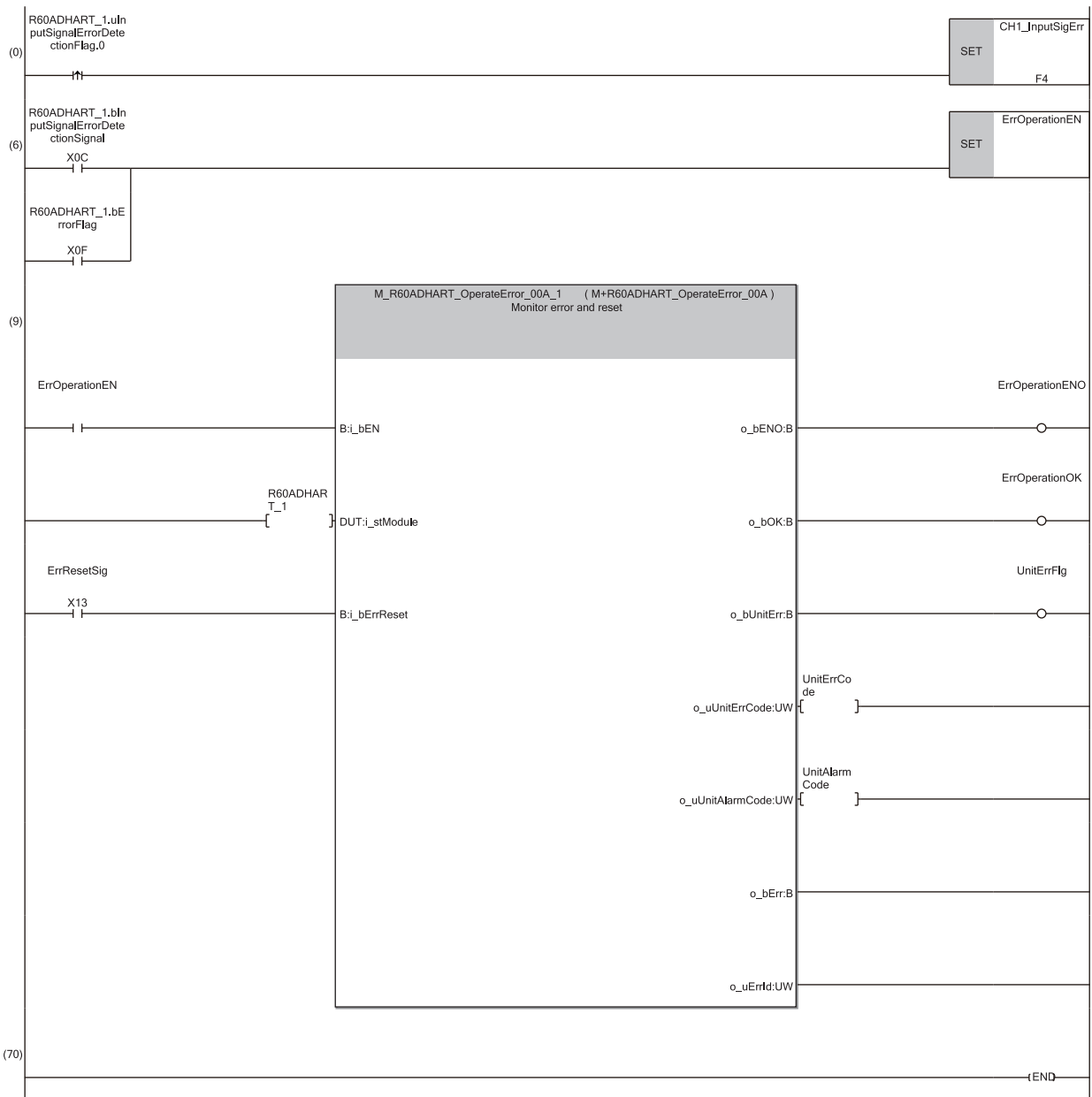

(0) The processing at the time when an input signal error is detected in CH1 is to be performed.

(6) Error manipulation start flag is to be turned on.

Program example 6

This program is an example to read HART device variables from the HART-enabled device connected to CH2 or CH4 and save the read variables.

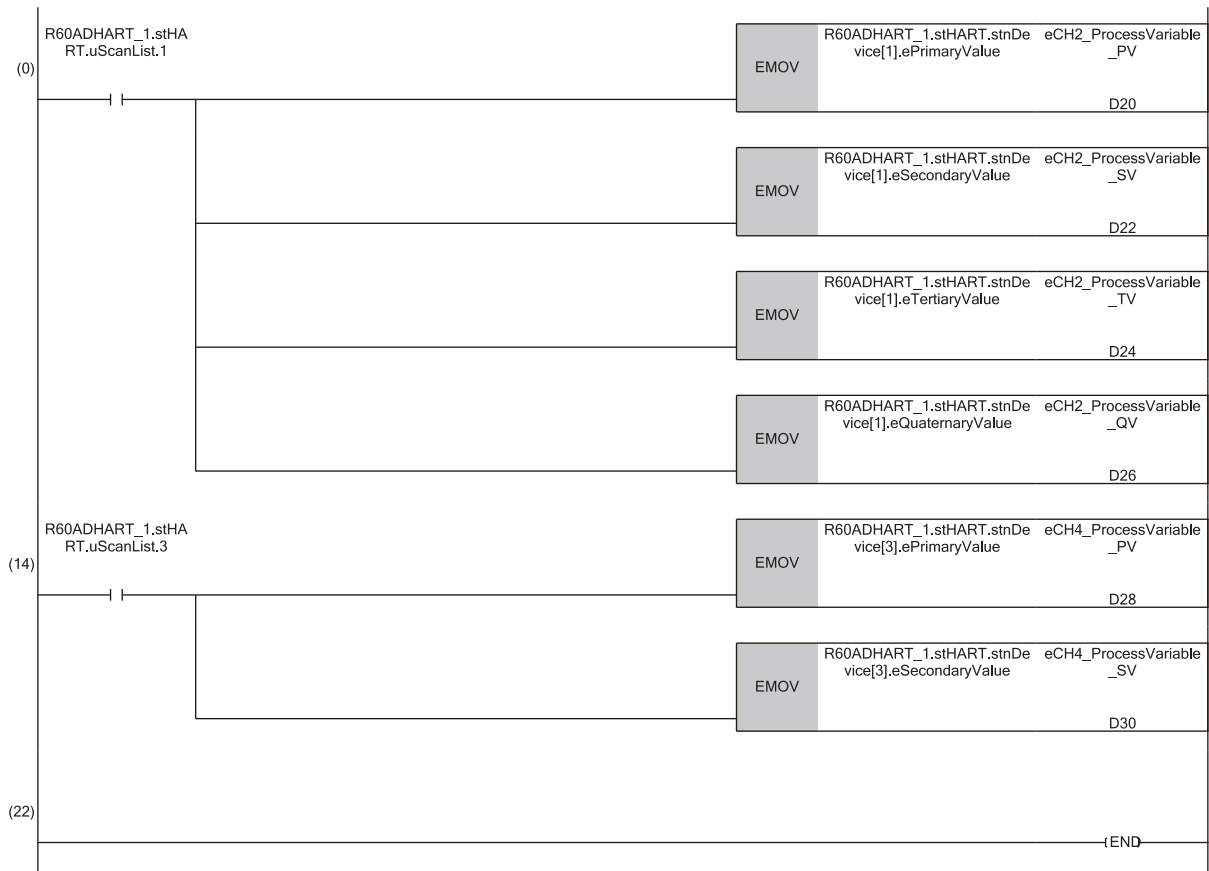

(0) PV value, SV value, TV value, and QV value of CH2 are to be read.

(14) PV value and SV value of CH4 are to be read.

APPENDICES

Appendix 1 I/O Conversion Characteristics

An I/O conversion characteristic of A/D conversion is expressed by the slope of the straight line connecting the offset value and the gain value at the time when an analog signal (current) from outside the programmable controller is converted to a digital output value.

Offset value

This value is the analog input value (current) where the corresponding digital output value is 0.

Gain value

This value is the analog input value (current) where the corresponding digital output value is 32000.

Current input characteristics

The following shows the lists of the analog input ranges at the current input and the graphs of the current input characteristics.

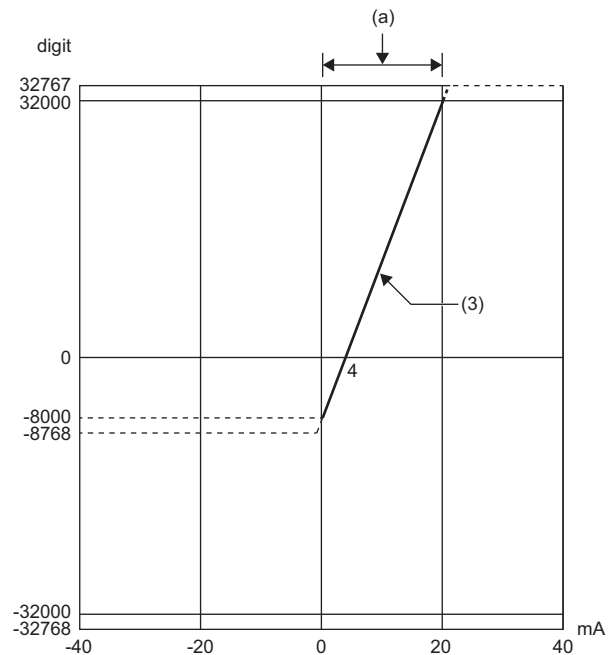
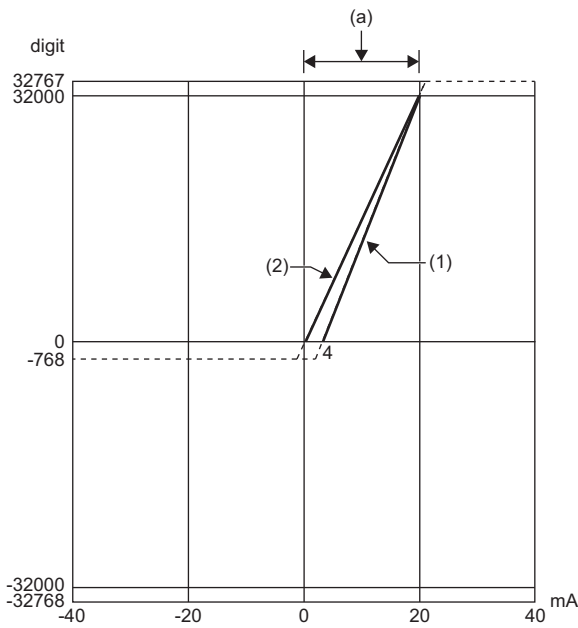

digit: Digital output value
 mA: Analog input current (mA)
 (a): Practical analog input range

No.	Input range setting	Offset value	Gain value	Digital output value*1	Resolution
(1)	4 to 20mA	4mA	20mA	0 to 32000	500.0nA
(2)	0 to 20mA	0mA	20mA		625.0nA
(3)	4 to 20mA (extended mode)	4mA	20mA	-8000 to 32000	500.0nA

*1 When analog input exceeds the range of the digital output value, the digital output value is fixed to the maximum or minimum.

Input range setting	Digital output value	
	Minimum	Maximum
4 to 20mA	-768	32767
0 to 20mA		
4 to 20mA (extended mode)	-8768	

Point

- Set values within the practical range of the analog input and digital output for each input range. If the values are out of the range, the resolution and accuracy may not fall within the range of the performance specifications. (Do not use values shown by the dotted lines in the graphs of current input characteristics.)
- The range of 4 to 20mA (extended mode) allows extending the lower limit value of analog input. The upper limit value of analog input cannot be extended.
- Do not set the current over 30mA. Doing so can cause breakdown of the elements.

A

Appendix 2 Accuracy

Accuracy of A/D conversion is determined by the maximum digital output value.

An input characteristic change through changes of the input range does not sacrifice the accuracy, which is maintained within the described range of the performance specifications.

The following graph shows the fluctuation range of accuracy when the range of 4 to 20mA is selected.

The accuracy is $\pm 0.1\%$ (± 32 digit) at ambient temperature of $25 \pm 5^\circ\text{C}$; the accuracy is $\pm 0.3\%$ (± 96 digit) at ambient temperature of 0 to 55°C (unless affected by noise).

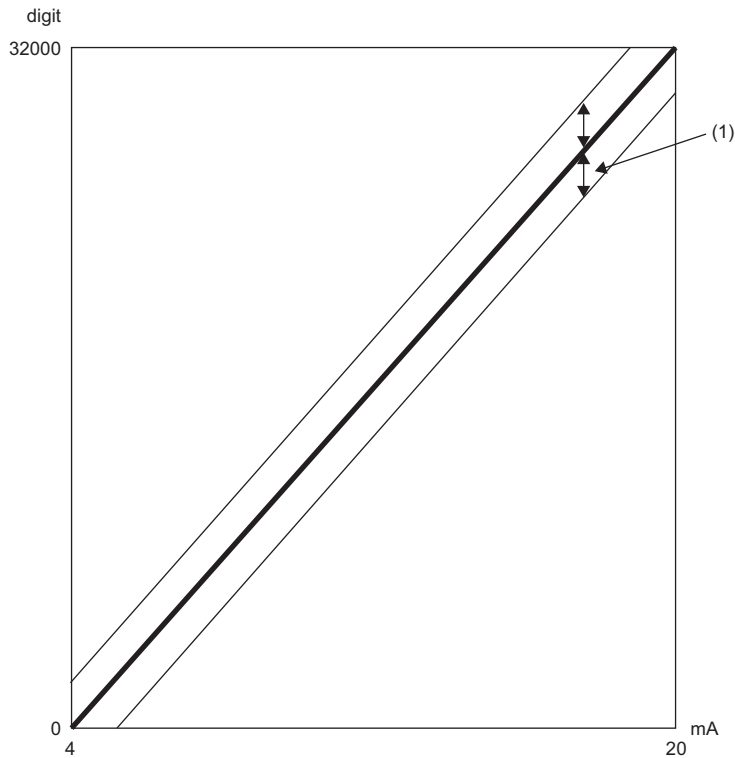

digit: Digital output value
mA: Analog input value (mA)
(1) Fluctuation range

Appendix 3 External Dimensions

The following figure shows the external dimensions of the A/D converter module.

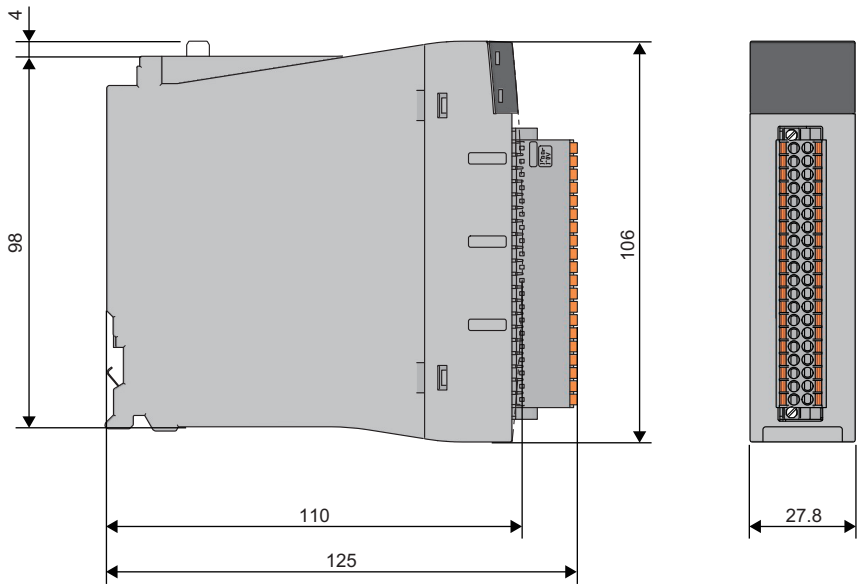

(unit: mm)

INDEX

A

Accuracy of A/D conversion	42
ALM LED	14

B

Buffer memory areas	13
-------------------------------	----

C

CommDTM (Communication DTM)	13
Current input characteristics	41

D

Device DTM	13
DTM (Device Type Manager)	13

E

Engineering tool	13
ERR LED	14

F

FDT (Field Device Tool)	13
FDT frame application	13

G

Gain value	40
Global label	13

I

I/O conversion characteristics	40
------------------------------------------	----

M

MELSOFT FieldDeviceConfigurator	13
Module label	13

O

Offset value	40
------------------------	----

P

Performance specifications	16
Production information marking	14
Program example	32

R

RUN LED	14
-------------------	----

T

Terminal block	14
--------------------------	----

W

Watchdog timer error	13
--------------------------------	----

MEMO

REVISIONS

*The manual number is given on the bottom left of the back cover.

Revision date	*Manual number	Description
October 2018	SH(NA)-082047ENG-A	First edition

Japanese manual number: SH-082045-A

This manual confers no industrial property rights of any other kind, nor does it confer any patent licenses. Mitsubishi Electric Corporation cannot be held responsible for any problems involving industrial property rights which may occur as a result of using the contents noted in this manual.

© 2018 MITSUBISHI ELECTRIC CORPORATION

WARRANTY

Please confirm the following product warranty details before using this product.

1. Gratis Warranty Term and Gratis Warranty Range

If any faults or defects (hereinafter "Failure") found to be the responsibility of Mitsubishi occurs during use of the product within the gratis warranty term, the product shall be repaired at no cost via the sales representative or Mitsubishi Service Company.

However, if repairs are required onsite at domestic or overseas location, expenses to send an engineer will be solely at the customer's discretion. Mitsubishi shall not be held responsible for any re-commissioning, maintenance, or testing on-site that involves replacement of the failed module.

[Gratis Warranty Term]

The gratis warranty term of the product shall be for one year after the date of purchase or delivery to a designated place. Note that after manufacture and shipment from Mitsubishi, the maximum distribution period shall be six (6) months, and the longest gratis warranty term after manufacturing shall be eighteen (18) months. The gratis warranty term of repair parts shall not exceed the gratis warranty term before repairs.

[Gratis Warranty Range]

- (1) The range shall be limited to normal use within the usage state, usage methods and usage environment, etc., which follow the conditions and precautions, etc., given in the instruction manual, user's manual and caution labels on the product.
- (2) Even within the gratis warranty term, repairs shall be charged for in the following cases.
 1. Failure occurring from inappropriate storage or handling, carelessness or negligence by the user. Failure caused by the user's hardware or software design.
 2. Failure caused by unapproved modifications, etc., to the product by the user.
 3. When the Mitsubishi product is assembled into a user's device, Failure that could have been avoided if functions or structures, judged as necessary in the legal safety measures the user's device is subject to or as necessary by industry standards, had been provided.
 4. Failure that could have been avoided if consumable parts (battery, backlight, fuse, etc.) designated in the instruction manual had been correctly serviced or replaced.
 5. Failure caused by external irresistible forces such as fires or abnormal voltages, and Failure caused by force majeure such as earthquakes, lightning, wind and water damage.
 6. Failure caused by reasons unpredictable by scientific technology standards at time of shipment from Mitsubishi.
 7. Any other failure found not to be the responsibility of Mitsubishi or that admitted not to be so by the user.

2. Onerous repair term after discontinuation of production

- (1) Mitsubishi shall accept onerous product repairs for seven (7) years after production of the product is discontinued. Discontinuation of production shall be notified with Mitsubishi Technical Bulletins, etc.
- (2) Product supply (including repair parts) is not available after production is discontinued.

3. Overseas service

Overseas, repairs shall be accepted by Mitsubishi's local overseas FA Center. Note that the repair conditions at each FA Center may differ.

4. Exclusion of loss in opportunity and secondary loss from warranty liability

Regardless of the gratis warranty term, Mitsubishi shall not be liable for compensation to:

- (1) Damages caused by any cause found not to be the responsibility of Mitsubishi.
- (2) Loss in opportunity, lost profits incurred to the user by Failures of Mitsubishi products.
- (3) Special damages and secondary damages whether foreseeable or not, compensation for accidents, and compensation for damages to products other than Mitsubishi products.
- (4) Replacement by the user, maintenance of on-site equipment, start-up test run and other tasks.

5. Changes in product specifications

The specifications given in the catalogs, manuals or technical documents are subject to change without prior notice.

TRADEMARKS

The company names, system names and product names mentioned in this manual are either registered trademarks or trademarks of their respective companies.

In some cases, trademark symbols such as '™' or '®' are not specified in this manual.

SH(NA)-082047ENG-A(1810)MEE

MODEL: R60ADI8-HA-U-IN-E

MODEL CODE: 13JX96

mitsubishi electric corporation

HEAD OFFICE : TOKYO BUILDING, 2-7-3 MARUNOUCHI, CHIYODA-KU, TOKYO 100-8310, JAPAN
NAGOYA WORKS : 1-14, YADA-MINAMI 5-CHOME, HIGASHI-KU, NAGOYA, JAPAN

When exported from Japan, this manual does not require application to the
Ministry of Economy, Trade and Industry for service transaction permission.

Specifications subject to change without notice.